

DISTRIBUTED BY  
**saniflex ab**  
[www.saniflex.se](http://www.saniflex.se)

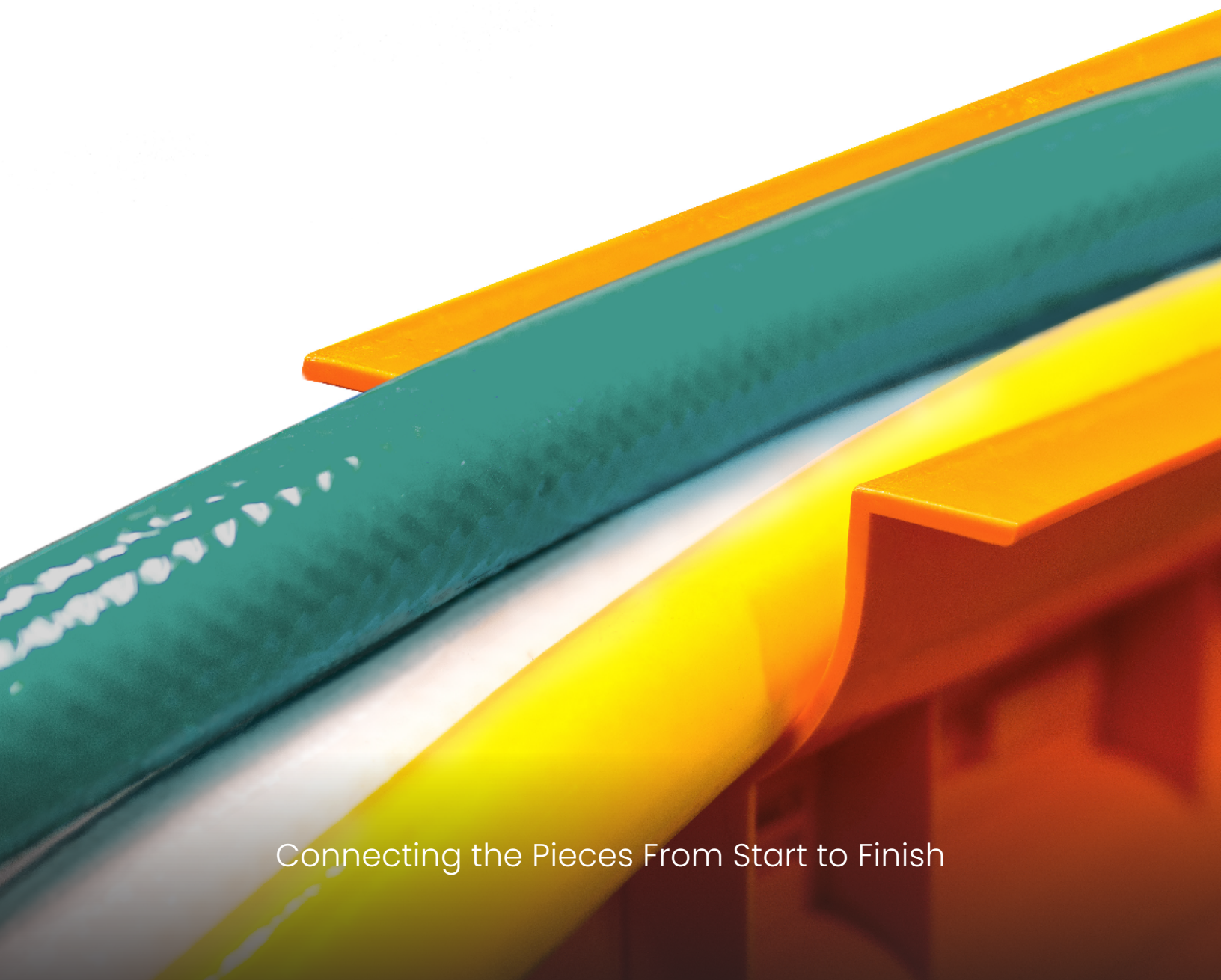

# Hose Holders

By **AdvantaPURE**  
NEW AGE INDUSTRIES



Connecting the Pieces From Start to Finish

## COMPLIANT SOLUTION TO TUBING MANAGEMENT

Hose Holders by AdvantaPure® is the ultimate solution for safe and efficient hose management in biopharmaceutical manufacturing facilities. Designed specifically to maintain the integrity of biopharmaceutical operations, the Hose Holder reduces tripping hazards, contamination, and hose damage during the transfer of liquids from one vessel to another. Made of high-quality materials, it is designed to secure hoses of various sizes and

sits easily on any flat surface. Hose Holders by AdvantaPure helps improve cleanliness and organization by keeping hoses off the ground limiting tangles and kinking. Easy to assemble by aligning the raised notches on either side, it clicks in place to be used immediately with no tools needed for assembly or installation. The Hose Holder is an ideal solution for aiding safe and efficient fluid transfer by keeping your hoses off the floor.



*Hose management without  
Hose Holders*

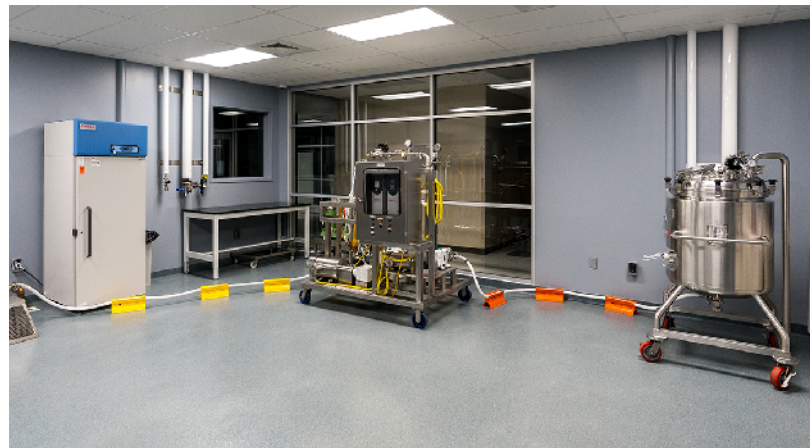

*Hose management with  
Hose Holders*

## FEATURES & BENEFITS

- Tubing & hose management solution for manufacturing
- Reduces potential contamination from the floor as hose is being handled
- Visible colors help reduce tripping hazards
- Easy to use, easy to clean and maintain
- Secures hoses of various sizes without needing to add equipment
- Disassemble for easy storage
- Custom colors may be available

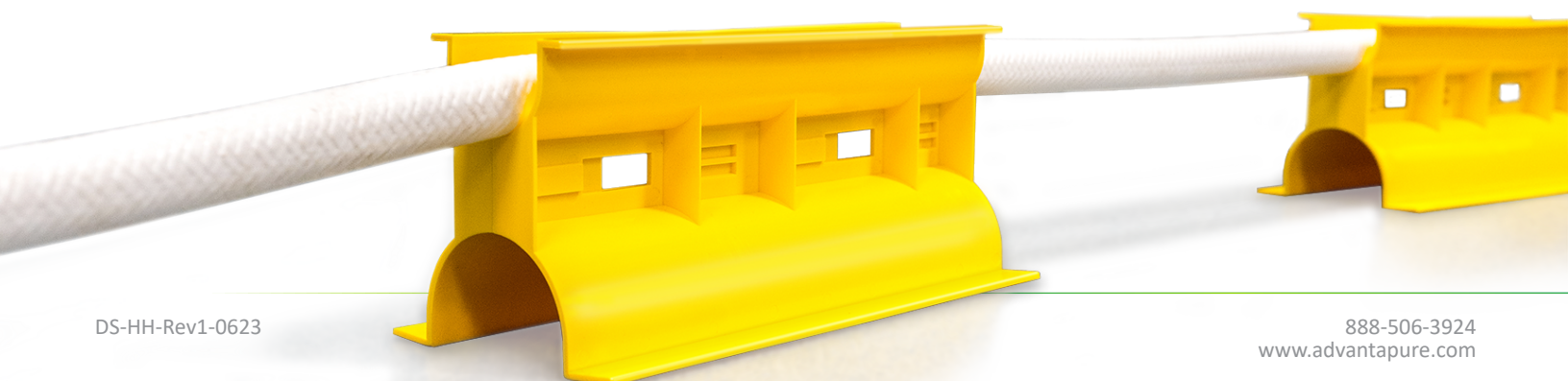

**TECHNICAL SPECS:**

Material:	HDPE	
Colors available:	Orange	Yellow
Part number:	HH1101000	HH1001000
Packaging:	Available in cases of 20 disassembled Hose Holders that are double bagged.	
Size:	12" L x 5" W x 5" H (305 mm x 127 mm x 127 mm) <i>when assembled</i>	

**MATERIAL REGULATORY INFORMATION:**

REACH  
 Animal-derived component-free (ADCF)  
 USP Class VI  
 USP 661

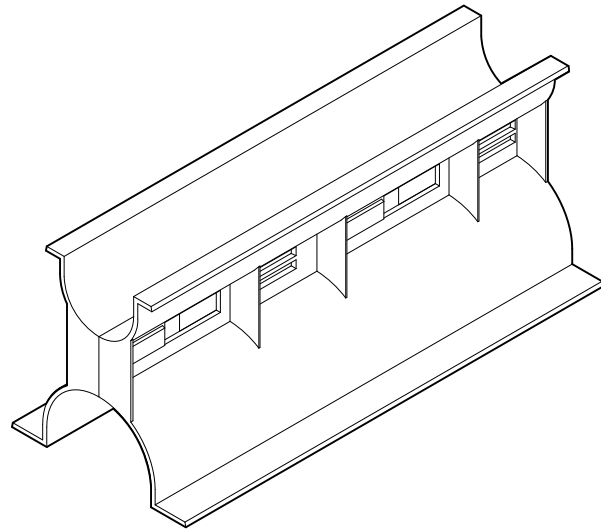

*Iso view when assembled*

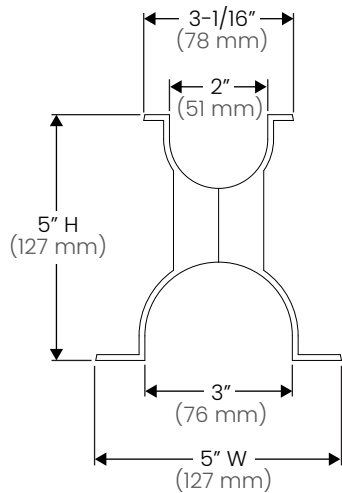

*Front view when assembled*

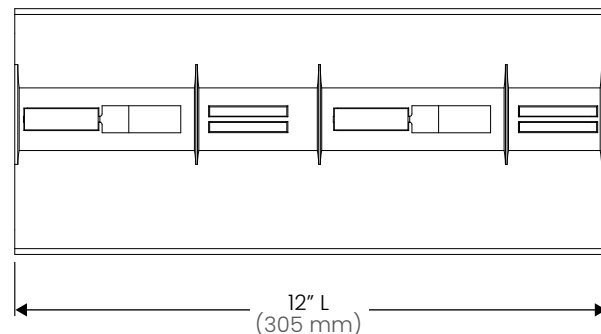

*Side view when assembled*

DISTRIBUTED BY  
**saniflex ab**  
www.saniflex.se



**WARRANTY:** NewAge Industries AdvantaPure products are warranted to be free from defects in material and workmanship. Any product found to carry such defects will be replaced without charge. This warranty is limited only to the replacement of NewAge Industries AdvantaPure products, item for item, which after examination by NewAge Industries AdvantaPure are deemed defective. NewAge Industries AdvantaPure specifically disclaims any other liability. The data supplied is provided as a helpful guideline and is believed to be reliable; however, nothing stated shall constitute a guarantee, recommendation, or warranty for any application.

**NOTICE:** NewAge Industries, Inc. has been a privately owned corporation since 1954. Neither the corporation nor its principals are affiliated, in any way, with any other group or entity either representing themselves as or being referred to by the term New-Age.

© Copyright 2023. All Rights Reserved



145 James Way · Southampton, Pennsylvania 18966 USA  
**888-506-3924 · 215-526-2300**

AdvantaPure®, AdvantaFlex®, NewAge®, and "Fluid Transfer Specialists®" are registered trademarks of NewAge Industries, Inc.

Reproducing this document or any part thereof, in any form whatsoever, is prohibited without express written permission of NewAge Industries, Inc.

To learn more about NewAge Industries  
and what solutions we offer visit:

**www.advantapure.com**  
**www.newageindustries.com**  
**info@newageindustries.com**