

SINGLE-USE PROCESS SYSTEMS

FOR PHARMACEUTICAL & BIOTECH PROCESSING APPLICATIONS



Single-use process systems eliminate lengthy production stoppages for sterilization between batch runs, thereby simplifying cleaning validation requirements—use once and discard.

By combining platinum-cured, Class VI silicone tubing with molded fittings, stoppers and other components, a wide variety of manifold options are possible. Designs range from simple, single fitting connections to complex configurations with varying lengths of tubing and several molded connections.

Single-Use Systems are not intended for implantation and are not to be used for continuous steam applications.



KEY FEATURES



- Custom manufactured with Y's, T's, crosses, reducers, mini and standard Tri-Clamps®, stoppers, other container closures, and tubing—many configurations are available
- Eliminates entrapment issues and leaks associated with barbed fittings
- Components are permanently molded into one, single-use manifold
- Reduces the risk of cross contamination
- Reduces production downtime by eliminating certain cleaning validation requirements
- Provides a smooth inner surface without seams or crevices for even, uninterrupted flow
- Reduces end-user assembly labor time and expense
- Retains silicone's wide range of temperature resistance: -100°F to 400°F
- Provides flexibility in facility design—changes are less costly than with hard piping
- Sterilizable by autoclave and gamma radiation
- Imparts no taste or odor to critical streams
- Manufactured and sealed in clear polybags in a controlled environment to ensure cleanliness
- Documented lot traceable with identification on bags
- Documented quality control
- Experienced engineers available for technical assistance
- Tubing and molded silicone connections provide one material contact surface throughout the assembly
- Optional RFID tags easily attach to assemblies for identification purposes providing reliable electronic data storage and current status of assemblies from inception to disposal

SILICONE

www.advantapure.com

SINGLE-USE PROCESS SYSTEMS

FOR PHARMACEUTICAL & BIOTECH PROCESSING APPLICATIONS

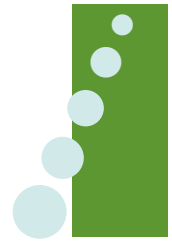

This example of an assembly made from tubing and barbed fittings is comprised of nine separate pieces of tubing of varying sizes and lengths, plus four fittings that require insertion into the tubing at three points each, with double ties wraps installed at each connection for secure attachment.

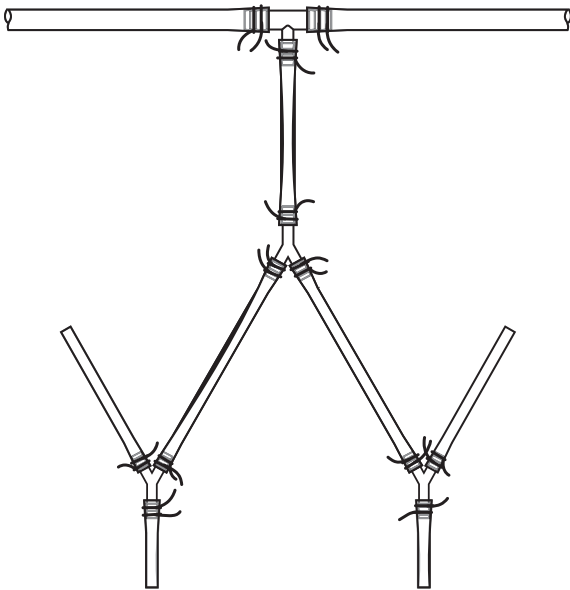

37 components

An AdvantaPure Single-Use Process System is a complete unit, packaged in a sealed polybag and ready for use. Leaks, entrapment, and contamination concerns involved with barbed fitting connections are eliminated. Labor, numerous inventories, and time to assemble the manifold is unnecessary.

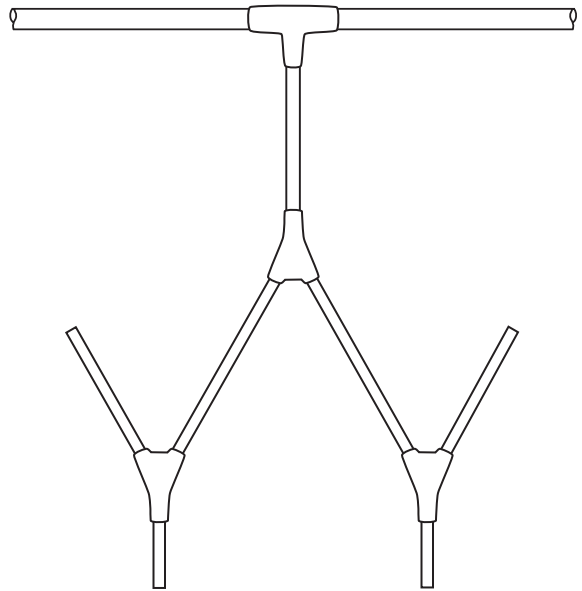

1 component

SILICONE



■ Select from a number of different crevice-free connections.



■ Silicone tubing is available from stock in nearly 50 sizes. It, too, is platinum cured and meets Class VI standards. Complete biocompatibility validation packages are available.



Phone: 215-526-2151 Toll Free Phone: 888-755-4370

www.advantapure.com

■ Stoppers and stopper assemblies are manufactured from platinum-cured, Class VI silicone and are available solid, with holes, and with tubing inserts. They can easily become part of your manifold design for batch processing in a variety of sampling and storage containers made from glass, plastics, or metal.



■ Molded silicone Tri-Clamp® fittings with protective backing cups may be incorporated into process systems.

Experienced engineers with 20 years of knowledge in silicone extrusion and molding are available for technical assistance.

SILICONE

■ True Union silicone stoppers, GL45, and various other container closures, available with or without tubing inserts or holes, are also manufactured from platinum-cured, Class VI silicone.



SINGLE-USE PROCESS SYSTEMS

FOR PHARMACEUTICAL & BIOTECH PROCESSING APPLICATIONS



Customized Visual Identification

- Each manifold is assigned a unique identification number
- Include part number, manufactured date, planned replacement date, or any specific information you deem critical
- Add color striping for quick line identification – 10 standard colors available
- Permanently vulcanized silicone
- Easy-to-read label remains bright white after repeated sterilization
- Handles clean-in-place (CIP) or steam-in-place (SIP) processes
- Autoclavable
- Gamma sterilizable
- Each individual manifold identification number can be linked to the AdvantaPure website to access related documentation and certifications

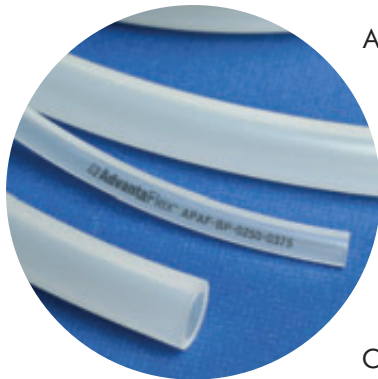
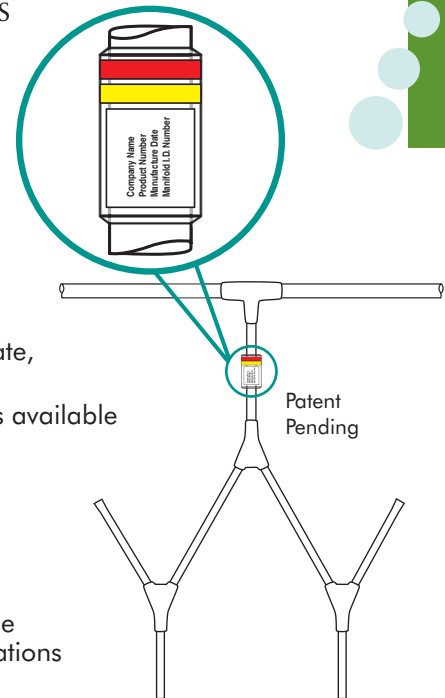

AdvantaFlex addresses the need for a flexible, translucent, heat sealable, and weldable tubing for fluid processing applications.

AdvantaFlex may be attached to single-use biobags and manifolds, and it's sterilizable by autoclave or gamma radiation. Additionally, the unique properties of this special formulation help it perform better than other tubing in critical stream transfer lines and peristaltic pumps.

AdvantaFlex has been thoroughly tested. A full extractables study is available, along with complete validation documentation.

Contact your AdvantaPure sales representative or visit www.advantapure.com/advantaflex.htm for information.



Purity in Fluid Flow SystemsSM



Made in U.S.A.

Address: NewAge® Industries AdvantaPure®
145 James Way
Southampton, PA 18966 U.S.A.

Toll Free Phone: **888-755-4370**
Phone: **215-526-2151**
Toll Free Fax: **888-258-4293**
Fax: **215-526-2167**
Web Site: **www.advantapure.com**
E-mail: **sales@advantapure.com**



DISTRIBUTED BY:

saniflex ab

Dalénium 33, 181 70 LIDINGÖ, SWEDEN
Tel: +46 (0)8-7652979, Fax: +46 (0)8-7654030,
E-mail: saniflex@saniflex.se
Website: www.saniflex.se



©2008 NewAge® Industries, Inc.
AdvantaPure products are produced by NewAge® Industries, Inc.
AdvantaFlex™, NewAge® Industries AdvantaPure®, the AdvantaPure logo,
NewAge® and the "N" logo are trademarks of NewAge® Industries, Inc.
Purity in Fluid Flow Systems™ is a service mark of NewAge® Industries, Inc.
Tri-Clamp® registered trademark of the Ladish Co., Tri-Clover Div.

WARRANTY: NewAge Industries AdvantaPure products are warranted to be free from defects in material and workmanship. Any product found to carry such defects will be replaced without charge. This warranty is limited only to the replacement of NewAge Industries AdvantaPure products, item for item, which after examination by NewAge Industries AdvantaPure are deemed defective. NewAge Industries AdvantaPure specifically disclaims any other liability. The data supplied is provided as a helpful guideline and is believed to be reliable; however, nothing stated shall constitute a guarantee, recommendation, or warranty for any application.

NOTICE: NewAge Industries, Inc. has been a privately owned corporation since 1954. Neither the corporation nor its principals are affiliated, in any way, with any other group or entity either representing themselves as or being referred to by the term New-Age.



ESOP Employee Owned
for Your Benefit

Celebrating over
50
Years
of Service
1954-2008